



KV Series Pump | Submittal Data

Vertical Close Coupled Pumps

Submittal No: 301-1090D | Model: 4009D | RPM: 1160 - 60 Hz | Effective: December 31, 2019 | Supersedes: New

JOB: _____

REPRESENTATIVE: _____

ENGINEER: _____

CONTRACTOR: _____

PRODUCT DATA

ITEM NO. _____ MODEL NO. 4009D

IMPELLER DIAMETER _____ HORSEPOWER _____

GPM _____ VOLTAGE _____

HEAD/FT _____ RPM 1160

WEIGHT _____ PUMP/MOTOR _____

SUPPORT STAND OPTION YES NO

(Ductile Iron ASTM A536-84 Grade 65-45-12)

DIMENSIONS

Model No. | 4009D

Flange Size (Suction x Discharge) | 4 x 4 (102 x 102)

HORSEPOWER	1.5	2	3	5
MOTOR FRAME TEFC	182JM	184JM	213JM	215JM
MOTOR FRAME ODP	182JM	184JM	213JM	215JM
WEIGHT WITHOUT OPTIONAL STAND LBS (KG)	291.0 (132)	322.9 (146)	383.4 (174)	398.8 (181)
WEIGHT WITH OPTIONAL STAND LBS (KG)	342.9 (156)	374.8 (170)	435.3 (197)	450.7 (204)
FLANGE SIZE ASA	4 (102)			
A*	ANSI CLASS 125: 12.5 (318)			
	ANSI CLASS 250: 12.82 (326)			
B*	ANSI CLASS 125: 12.5 (318)			
	ANSI CLASS 250: 12.82 (326)			
C	6.77 (172)			
D	12.59 (320)			
E MAX	13.76 (350)	15.26 (388)	16.64 (423)	18.11 (460)
F	7.29 (185)			
G	8.44 (214)			
J DIA	7.88 (200)		9.56 (243)	
K	4			
L	3/8-16 UNC-2B			
M	4.87 (124)			
N	6.5 (165)			
P	12.63 (321)			
Q	0.75 (19)			
R	10.63 (270)			

Configuration	DOE Basic Model Number	PEI Value		Energy Rating
		PEI _{cl}	N/A	
Bare Pump	N/A	PEI _{cl}	N/A	N/A
Pump + Motor	N/A	PEI _{cl}	N/A	N/A

N/A=NOT WITHIN DOE SCOPE

OPERATING SPECIFICATIONS

FLANGE	PRESSURE	TEMPERATURE
ANSI Class 125	175 PSIG* (1210 KPA)	250°F (120°C)
ANSI Class 250	300 PSIG** (2070 KPA)	250°F (120°C)

Motors: All NEMA Standard (JM Frame)

* In accordance with ANSI Standard B16.1 Class 125

** In accordance with ANSI Standard B16.1 Class 250

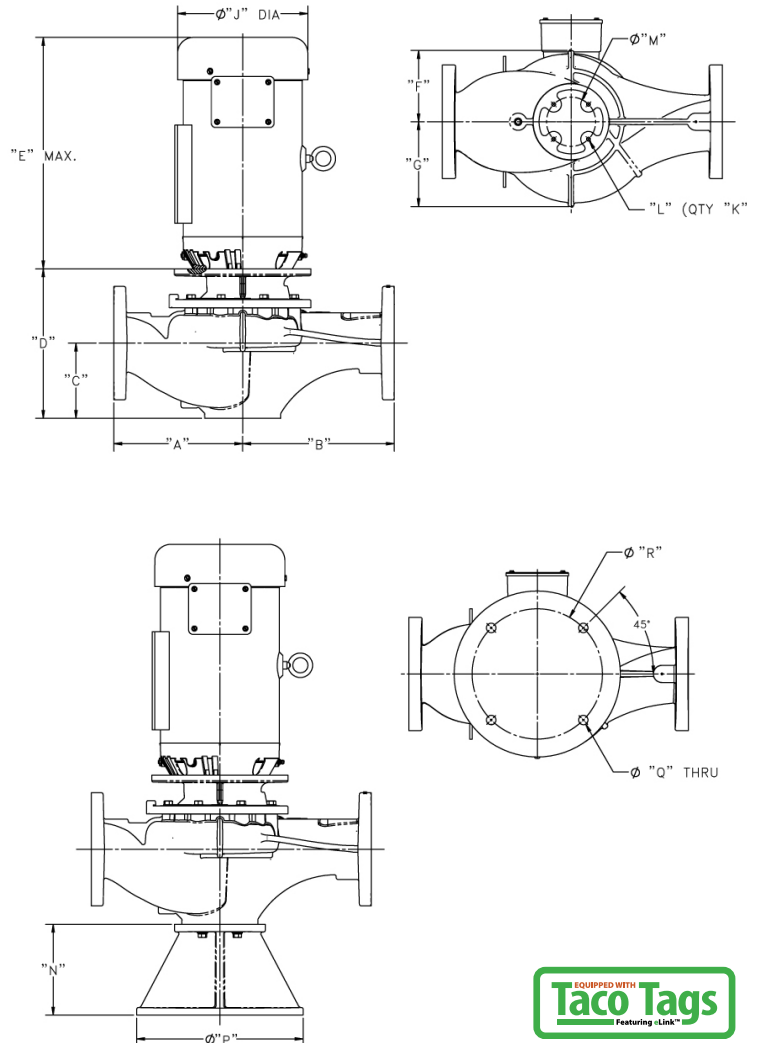

*A & B Dimensions apply for all pump sizes.

English dimensions are in inches. Metric dimensions are in millimeters. Metric data is presented in (). Do not use for construction purposes unless certified.



MATERIALS OF CONSTRUCTION			CASING	COVER	IMPELLER	WEAR RING	SHAFT	SHAFT SLEEVE	MECHANICAL SEAL	SEAL FLUSH LINE ASSEMBLY	SUPPORT STAND
STANDARD CONSTRUCTION	BRONZE FITTED	125# FLANGE	Cast Iron ASTM A48/A48M-03 Class 30A	Cast Iron ASTM A48/A48M-03 Class 30A	Bronze ASTM B584 ALLOY C83600 or C84400	N/A	Carbon Steel	Bronze ASTM B584-98A C92200	Ceramic/EPT	Copper & Brass C3600	N/A
		250# FLANGE	Ductile Iron ASTM A536-84 Grade: 65-45-12	Cast Iron ASTM A48/A48M-03 Class 30A	Bronze ASTM B584 ALLOY C83600 or C84400	N/A	Carbon Steel	Bronze ASTM B584-98A C92200	Ceramic/EPT	Copper & Brass C3600	N/A
OPTIONAL		125# OR 250#	N/A	N/A	Stainless Steel ASTM A351/A 351M-08	Bronze ASTM B584-98A C92200	N/A	Stainless Steel TYPE 303 ASTM A276	Tungsten Carbide/EPT or Silicon-Carbide/EPT	N/A	Ductile Iron ASTM A536-84 Grade 65-45-12

N/A - Not Available



KV Series | Model: 4009D | 1160 RPM

Curve No. 4356 | Min. Imp. Dia. 6.75" | Size 4x4x9.5 | December 18, 2019

Energy Efficiency Rating: DOE Basic Model Number: N/A @1160RPM
Pump & Motor: PE_{CL}: N/A @1160RPM

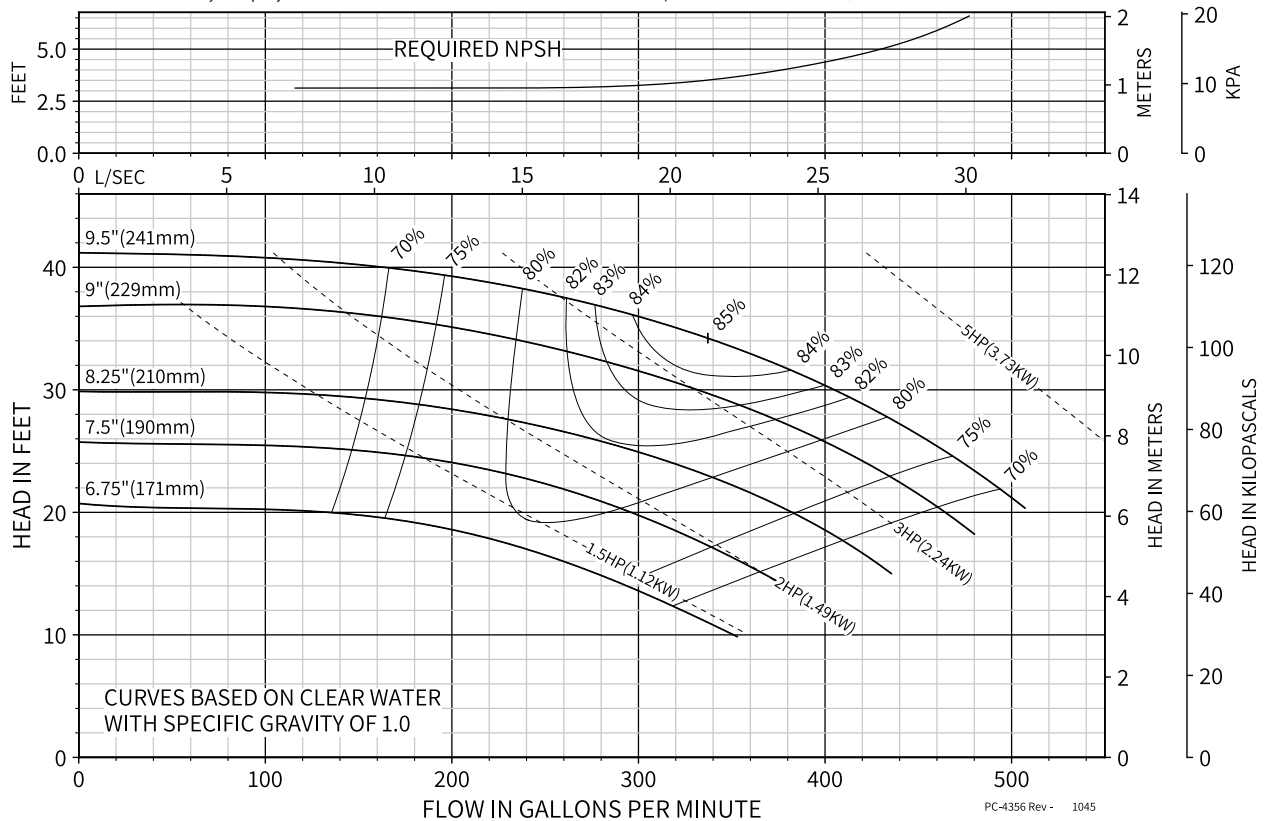

COMMENTS



Vertical Pumps Model:

Tag: P-2

- Flow Rate (GPM):** 194
- Head (FT):** 22
- Working Fluid:** Water @ 60 F
- Efficiency (%):** 78%
- Construction:** Iron
- Design Hp:** 1.38
- Nol Hp:** 1.85
- Motor Hp:** 1.50
- Npsh (Ft):** 3
- RPM:** 1160
- Imp Dia:** 7.20
- Volt/Ph/Hz:** 460/3/60
- Notes:**



KV Series | Model: 4009D | 1160 RPM

Curve No. 4356 | Min. Imp. Dia. 6.75" | Size 4x4x9.5 | December 18, 2019

Energy Efficiency Rating: DOE Basic Model Number: N/A @1160RPM
Pump & Motor: PEI_{CL}: N/A @1160RPM

